

# RM53

## miniature relays



- DC coils - of up to 24 V DC, low coil power 0,6 W (sensitive coil) or 0,8 W (standard coil)
- For PCB • Small dimensions, light weight
- High load up to 10 A / 120 V AC
- Applications: for household electrical appliance, automation systems, electrical equipment, instrument and meter, telecommunication devices, remote control facilities, light controllers, etc.
- Recognitions, certifications, directives: RoHS, 

### Contact data

Number and type of contacts	1 CO, 1 NO, 2 NO ①		
Contact material	<b>AgSnO<sub>2</sub></b>		
Rated / max. switching voltage	AC	250 V / 277 V	
	DC	14 V / 30 V	
Rated load	AC1	1 CO: 5 A / 5 A (NO/NC) / 250 V AC	1 NO, 2 NO: 5 A / 250 V AC
		1 CO: 10 A / 120 V AC	1 NO, 2 NO: 10 A / 120 V AC
	DC1	1 CO: 20 A / 10 A (NO/NC) / 14 V DC	1 NO, 2 NO: 20 A / 14 V DC
Motor load	acc. to UL 508	1/2 HP	125 V AC, single-phase motor
TV load		TV-5	
Max. make current		30 A ②	
Rated current		5 A	
Max. breaking capacity	AC1	1 250 VA	
	DC1	420 W	
Contact resistance		≤ 100 mΩ	
<b>Coil data</b>			
Rated voltage	DC	6, 9, 12, 24 V	
Must release voltage		DC: ≥ 0,05 U <sub>n</sub>	
Operating range of supply voltage		see Tables 1, 2	
Rated power consumption	DC	0,6 W sensitive coil	0,8 W standard coil
<b>Insulation according to EN 60664-1</b>			
Insulation resistance		≥ 100 MΩ	500 V DC
Dielectric strength	• between coil and contacts • contact clearance	500 V AC	50 Hz, type of insulation: reinforced
		500 V AC	50 Hz, type of clearance: micro-disconnection
<b>General data</b>			
Operating / release time (typical values)		≤ 10 ms / ≤ 5 ms	
Electrical life (number of cycles)	• resistive AC1 • resistive DC1	10 <sup>5</sup> 1 CO: 5 A / 5 A (NO/NC), 250 V AC	1 NO, 2 NO: 5 A, 250 V AC
		10 <sup>5</sup> 1 CO: 20 A / 10 A (NO/NC), 14 V DC	1 NO, 2 NO: 20 A, 14 V DC
Mechanical life		10 <sup>7</sup>	
Dimensions (L x W x H)		15,7 x 12,3 x 14 mm	
Weight		6 g	
Ambient temperature	• operating	-40...+85 °C	
(non-condensation and/or icing)			
Cover protection category		IP 67	EN 60529
Relative humidity		5...85%	
Shock resistance		98 m/s <sup>2</sup>	11 ms
Vibration resistance		1,5 mm DA (constant amplitude)	10...55 Hz
Solder bath temperature		max. 260 °C	
Soldering time		max. 5 s	

The data in bold type relate to the standard versions of the relays. Commonly used for automotive hazard indicator lights.

- ① Set of two normally open contacts with a common connection for the moving contact.  
② For the intermediate current, it only applies to the room temperature.

# RM53

miniature relays

## Dimensions ②

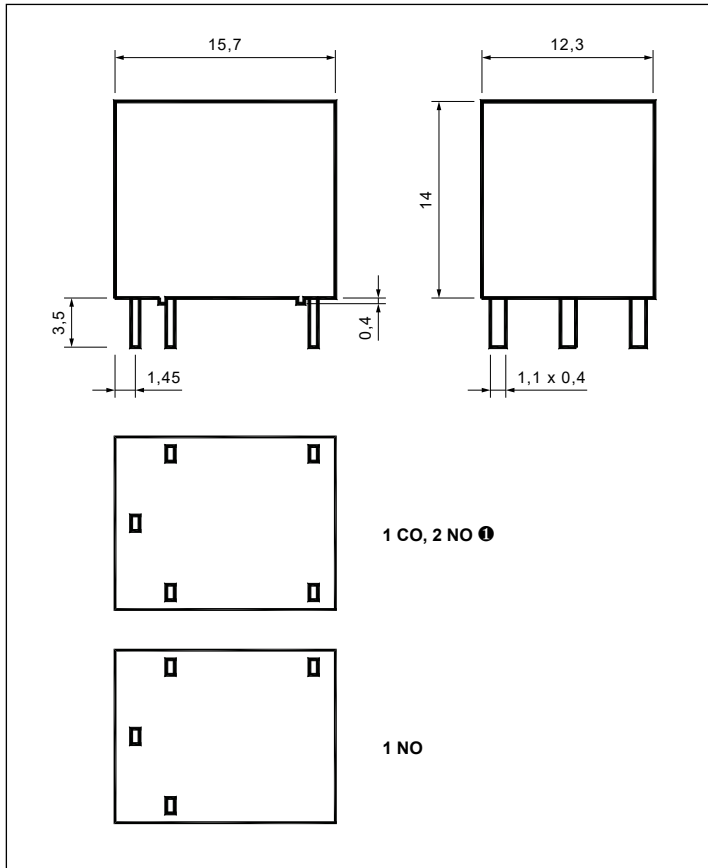

## Connection diagrams (pin side view)

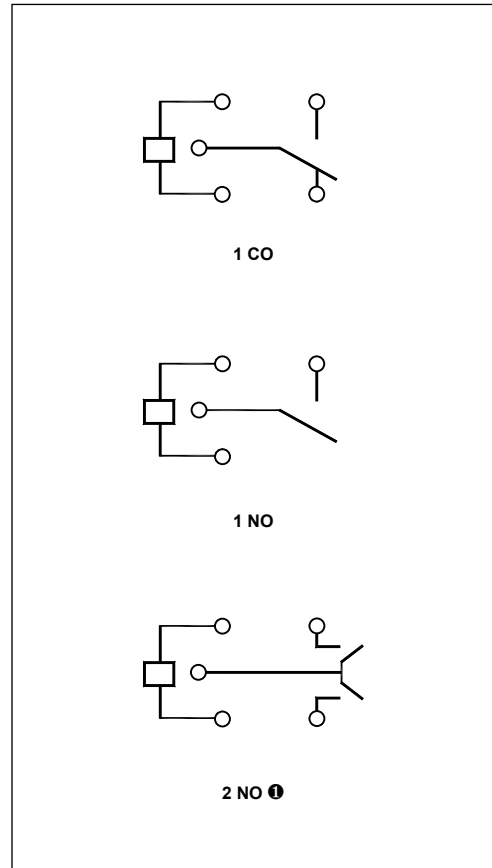

## Pinout (solder side view)

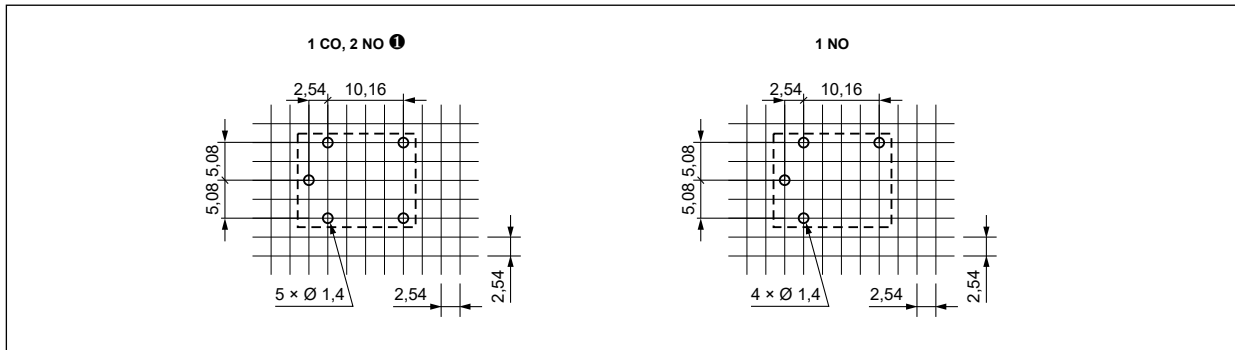

① Set of two normally open contacts with a common connection for the moving contact. ② In case of no tolerance shown in outline dimensions: outline dimension  $\leq 1$  mm tolerance should be  $\pm 0,2$  mm;  $> 1$  mm and  $\leq 5$  mm tolerance  $\pm 0,3$  mm;  $> 5$  mm tolerance  $\pm 0,4$  mm.

## Mounting

Relays **RM53** are designed for direct PCB mounting.

### PRECAUTIONS:

1. Ensure that the parameters of the product described in its specification provide a safety margin for the appropriate operation of the device or system and never use the product in circumstances which exceed the parameters of the product. 2. Never touch any live parts of the device. 3. Ensure that the product has been connected correctly. An incorrect connection may cause malfunction, excessive heating or risk of fire. 4. In case of any risk of any serious material loss or death or injuries of humans or animals, the devices or systems shall be designed so to equip them with double safety system to guarantee their reliable operation.

# RM53

miniature relays

**Coil data - DC voltage version, sensitive**

Table 1

Coil code	Rated voltage ④ V DC	Coil resistance at 20 °C Ω	Acceptable resistance	Coil operating range ④ V DC	
				min. (at 20 °C)	max. (at 20 °C)
S006	6	60	± 10%	4,8	6,6
S009	9	135	± 10%	7,2	9,9
S012	12	240	± 10%	9,6	13,2
S024	24	960	± 10%	19,2	26,4

**Coil data - DC voltage version, standard**

Table 2

Coil code	Rated voltage ④ V DC	Coil resistance at 20 °C Ω	Acceptable resistance	Coil operating range ④ V DC	
				min. (at 20 °C)	max. (at 20 °C)
1006	6	45	± 10%	4,8	6,6
1009	9	102	± 10%	7,2	9,9
1012	12	180	± 10%	9,6	13,2
1024	24	720	± 10%	19,2	26,4

④ The use of any coil voltage less than the rated coil voltage will compromise the operation of the relay. Pickup and release voltage are for test purposes only and are not to be used as design criteria.

## Ordering codes

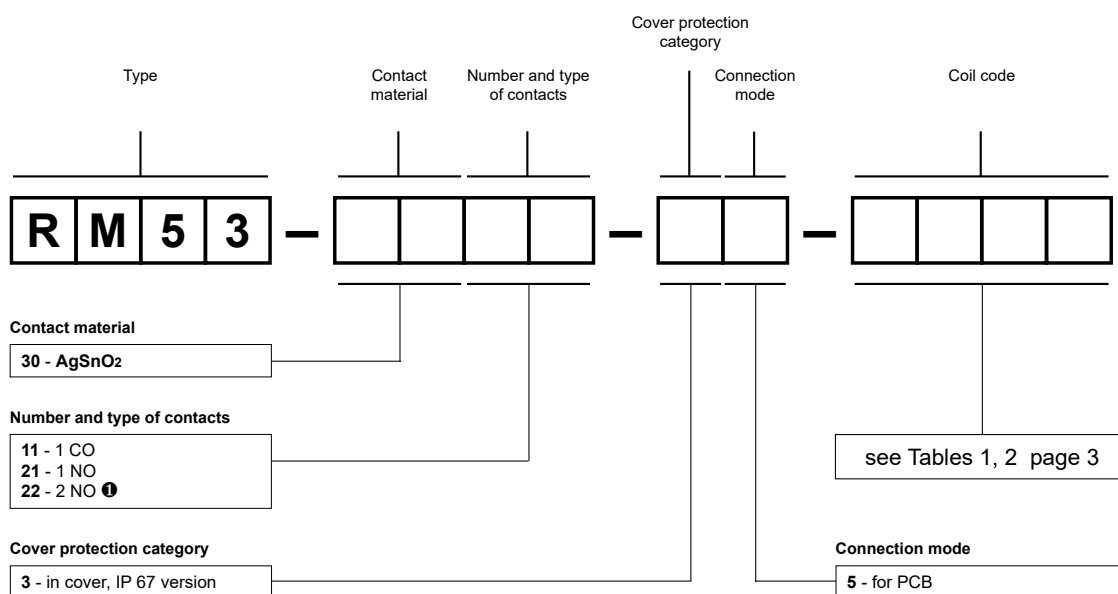

Examples of ordering codes:

- RM53-3011-35-S006** relay **RM53**, for PCB, one changeover contact, contact material AgSnO<sub>2</sub>, sensitive coil voltage 6 V DC, in cover IP 67
- RM53-3021-35-1012** relay **RM53**, for PCB, one normally open contact, contact material AgSnO<sub>2</sub>, standard coil voltage 12 V DC, in cover IP 67
- RM53-3022-35-1024** relay **RM53**, for PCB, two normally open contacts ①, contact material AgSnO<sub>2</sub>, standard coil voltage 24 V DC, in cover IP 67

① Set of two normally open contacts with a common connection for the moving contact.