

RPN-VM-A230

monitoring relays



RPN-1VM-A230



RPN-2VM-A230

NEW

- **Single-functions monitoring relays (AC voltage monitoring in 1-phase network - 1(N)~ 230 V)**
- Monitoring of exceeding the U_{min}/U_{max} threshold, phase failure
- Hysteresis mode • Adjustment of tripping delay
- Cadmium - free contacts 1 CO and 2 CO • AC input voltages
- Cover - modular, width 17,5 mm
- Direct mounting on 35 mm rail mount acc. to EN 60715
- Compliance with standard EN 50178
- Recognitions, certifications, directives: RoHS,

Output circuit - contact data

Number and type of contacts		1 CO	2 CO
Contact material		AgSnO ₂	
Max. switching voltage		300 V AC	
Rated load	AC1	12 A / 250 V AC	6 A / 250 V AC
	DC1	12 A / 24 V DC	6 A / 24 V DC
	DC1	0,3 A / 250 V DC	0,1 A / 250 V DC
Rated current		12 A / 250 V AC	6 A / 250 V AC
Max. breaking capacity	AC1	3 000 VA	1 500 VA
Min. breaking capacity		1 W 10 mA	
Contact resistance		≤ 100 mΩ	
Max. operating frequency			
• at rated load	AC1	600 cycles/hour	
Input circuit			
Supply voltage	AC	= monitoring voltage	
Rated voltage	50/60 Hz AC	1(N)~ 230 V	terminals A1-A2
Must release voltage		AC: ≥ 0,2 U _n	
Operating range of supply voltage		45...276 V	
Rated power consumption		≤ 1,3 W	
Range of supply frequency	AC	48...63 Hz	
Measuring circuit ①			
• measured value		electrical voltage, RMS value, 50 Hz 1(N)~ 230 V, sinus, 48...63 Hz	
• measuring inputs		= supply voltage AC: 1(N)~ 230 V	
• measuring terminals		A1-A2	
• measuring range		48...276 V	
• overload capacity		276 V	
• maximum instantaneous voltage (< 1 min.)		300 V	
• hysteresis H		± 6% of measured value	
• switching thresholds		MIN: 0,3...0,95 U _{max}	MAX: 160...276 V U _n
• switching thresholds for phase		ERROR: U _{min} (set) > U _m (measured) or U _{max} (set) < U _m (measured) OK: U _{min} (set) < U _m (measured) < U _{max} (set)	
Insulation according to EN 60664-1			
Insulation rated voltage		500 V AC	
Rated surge voltage		4 000 V 1,2 / 50 μs	
Overvoltage category		III	
Insulation pollution degree		2	
Flammability class		V-0	for modular cover, UL 94
Dielectric strength			
• input - output		4 000 V AC	type of insulation: basic
• contact clearance		1 000 V AC	type of clearance: micro-disconnection
• pole - pole		2 000 V AC	type of insulation: basic

① The measuring circuit is not galvanically insulated from the relay supply circuit.

RPN-VM-A230

monitoring relays

General data

Electrical life	• resistive AC1	> 0,5 x 10 ⁵	12 A, 6 A, 250 V AC
Mechanical life (cycles)		> 3 x 10 ⁷	
Dimensions (L x W x H)		90 \varnothing x 17,5 x 64,6 mm	
Weight		64,2 g	70,7 g
Ambient temperature	• storage	-40...+70 °C	
(non-condensation and/or icing)	• operating	-20...+60 °C	
Cover protection category		IP 20	EN 60529
Relative humidity		up to 85%	
Shock resistance		15 g	
Vibration resistance		0,35 mm DA	10...55 Hz
Measuring circuit data ①			
Functions		MINMAX - phase monitoring hysteresis mode	
Ranges of voltage		MIN - smooth adjustment: 30...95% U _{max} MAX - smooth adjustment: 160...276 V	
Time ranges of tripping delay		step adjustment: (0,1 s; 1 s; 2 s ②); 3 s; 4 s; 5 s; 6 s; 7 s; 8 s; 9 s	
Base accuracy		voltage measurement: \pm 5% ③	
Accuracy of delay time settings		threshold limits: \pm 6% ④ ⑤	
Repeatability		threshold limits: \pm 6% ⑥	
Values affecting the timing adjustment		• temperature \pm 0,05% / °C • supply voltage \pm 0,01% / V	
Recovery time		\leq 200 ms	
LED indicator ⑦		green LED U - indication of supply voltage U red LED E - indication of error, tripping delay yellow LED R - output relay status	

① The measuring circuit is not galvanically insulated from the relay supply circuit. ② Length with 35 mm rail catches: 98,8 mm. ③ For initial ranges (0,1 s; 1 s; 2 s) setting accuracy and repeatability are smaller than the given ones in technical parameters (significant influence of the operational relay operating time, processor start-time, and the moment of supply switching as referred to the AC supply course). ④ From a measured value in the range of 100...230 V. ⑤ Calculated from the final range values, for the setting direction from minimum to maximum. ⑥ LED indication - see "Additional functions", page 3.

Dimensions

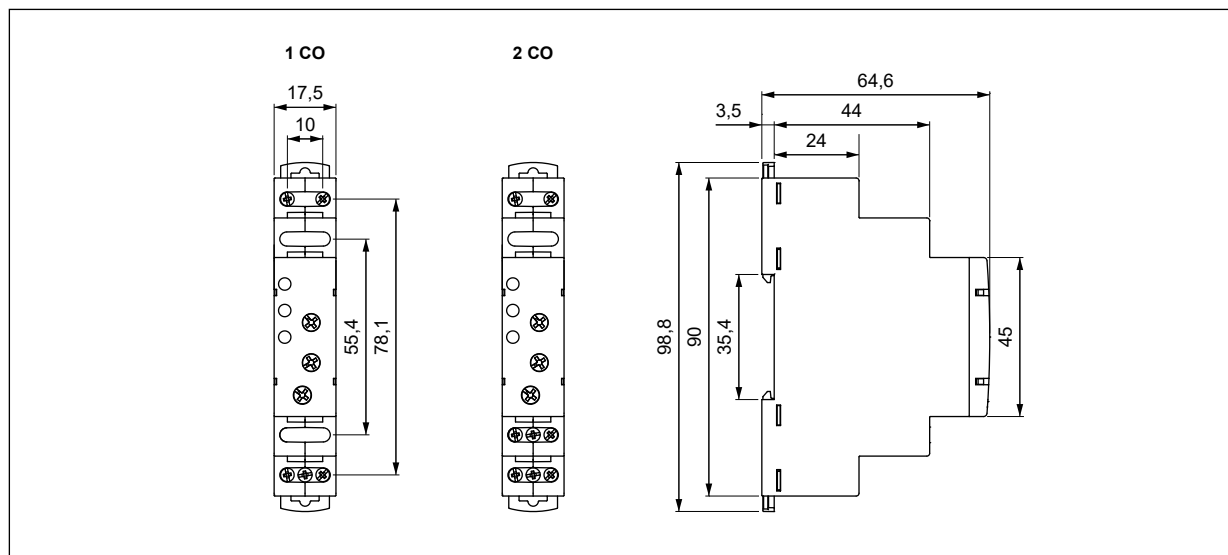

PRECAUTIONS:

1. Ensure that the parameters of the product described in its specification provide a safety margin for the appropriate operation of the device or system and never use the product in circumstances which exceed the parameters of the product. 2. Never touch any live parts of the device. 3. Ensure that the product has been connected correctly. An incorrect connection may cause malfunction, excessive heating or risk of fire. 4. In case of any risk of any serious material loss or death or injuries of humans or animals, the devices or systems shall be designed so to equip them with double safety system to guarantee their reliable operation.

Functions

MINMAX - Voltage monitoring between U_{min} and U_{max} values.

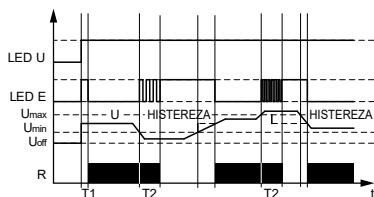

After applying the supply voltage between terminals A1 and A2 - when the voltage is between the preset thresholds U_{min} and U_{max} , after approximately 500 ms (time T1) the green diode U lights up and the operational relay R is switched on.

Minimum voltage monitoring (with delayed disconnection of contact R).

If the supply voltage drops below the preset threshold U_{min} , then the time T2 - switching off of the operational relay R - starts timing out. At the same time the red diode E slow flashes. When time T2 elapses, the red diode E lights up permanently and the operational relay R is switched off. If the supply voltage exceeds the voltage U_{min} increased by the value of hysteresis, then the red diode E goes off and the operational relay R is switched on.

Maximum voltage monitoring (with delayed disconnection of contact R).

If the supply voltage rises above the preset threshold U_{max} , then the time T2 - switching off of the operational relay R - starts timing out. At the same time the red diode E fast flashes. When time T2 elapses, the red diode E lights up permanently and the operational relay R is switched off. If the supply voltage is lower than voltage U_{max} minus the value of hysteresis, then the red diode E goes off and the operational relay R is switched on.

Phase failure monitoring (without delay for disconnection of contact R).

A drop of voltage below the threshold $U_{off} = 0,6 U_n$ (rated voltage) will immediately light up red diode E and immediately switch off the operational relay R.

U - supply voltage; **R** - output state of the relay;
T1, T2 - delay times; **t** - time axis

Additional functions

LEDs: red E is lit permanently or flashes at 500 ms and 250 ms period where it is lit for 50% of the time, and off for 50% of the time. Green U, yellow R - are lit permanently.

Adjustment of the set values: the values of range of voltage and tripping delay are read in the course of the relay's operation. The set values may be modified at any moment (without having to switch the relay power supply off and on again).

Supply: the relay may be supplied with AC voltage 48...63 Hz of 45...276 V.

LED indication	U	E	R
green does not light up	supply voltage cross the permitted range	-	-
green lights up all the time	supply voltage is within the permitted range	-	-
red does not light up ^①	-	output voltage within the set range of U_{min} and U_{max} and R contact closed	-
red lights up all the time	-	voltage not within the set range and for the time: from detection of power supply to activation of contact R	-
red slow flashes	-	time delay for the switch-off delay when the lower threshold of U_{min} is exceeded	-
red fast flashes	-	time delay for the switch-off delay when the upper threshold of U_{max} is exceeded	-
yellow does not light up	-	-	contact R disconnected
yellow lights up all the time	-	-	contact R connected

^① With supply voltage on (steady state).

RPN-VM-A230

monitoring relays

Front panel description

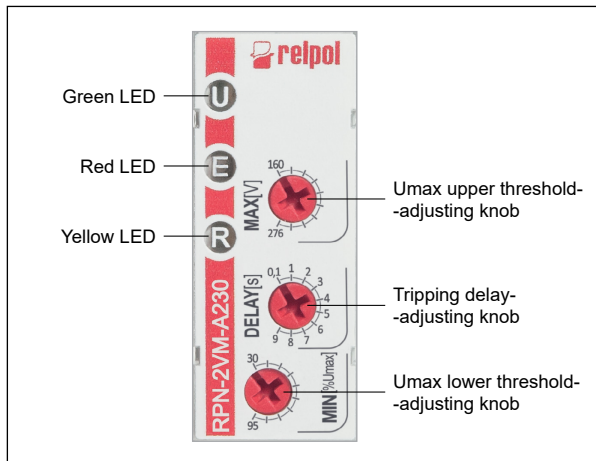

Connection diagrams

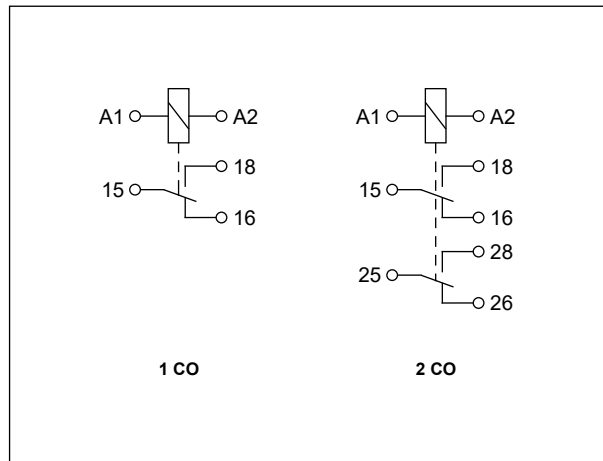

Mounting

Relays **RPN-VM-A230** are designed for direct mounting on 35 mm rail mount acc. to EN 60715. Operational position - any. **Connections:** max. cross section of the cables: 1 x 2,5 mm² (1 x 14 AWG), stripping length: 6,5 mm, max. tightening moment for the terminal: 0,5 Nm.

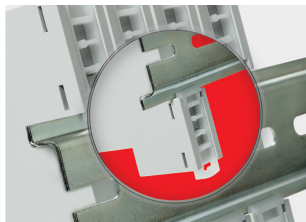

Two catches:
easy mounting
on 35 mm rail,
firm hold
(top and bottom).

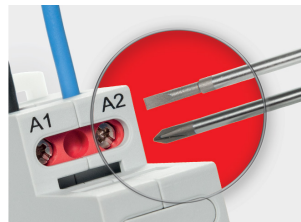

**Mounting wires
in clamps:**
universal screw
(cross-recessed
or slotted head).

Ordering codes

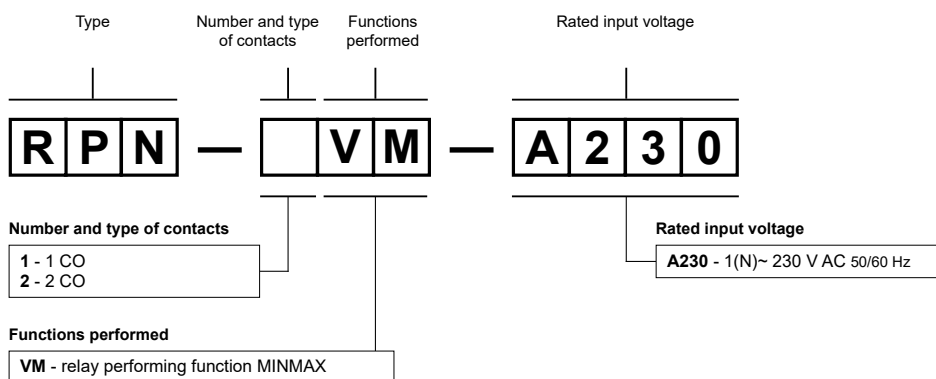

Examples of ordering codes:

- RPN-1VM-A230** monitoring relay **RPN-1VM-A230**, single-function (relay perform function MINMAX), cover - modular, width 17,5 mm, one changeover contact, contact material AgSnO₂, rated input voltage = monitoring 1(N)~ 230 V AC 50/60 Hz (with neutral wire)
- RPN-2VM-A230** monitoring relay **RPN-2VM-A230**, single-function (relay perform function MINMAX), cover - modular, width 17,5 mm, two changeover contacts, contact material AgSnO₂, rated input voltage = monitoring 1(N)~ 230 V AC 50/60 Hz (with neutral wire)