

RSR95

solid state relays, industrial



- DC load • DC control input
- MOSFET or IGBT output • Load current 7...100 A
- Load voltage 24...700 V DC
- Dielectric strength 2 500 Vrms (opto-isolation)
- Internal overvoltage protection
- LED indicator (red) • Screw terminals
- Mounting on panel or on heatsinks
- Recognitions, certifications, directives: RoHS, REACH, **CE ENEC**

Applications

DC power supplies, motors, fans, heaters, solenoid and electromechanical valves, battery sources, packaging machinery, transportation, medical and test equipment.



Basic technical data

Load voltage: 24 V DC, 36 V DC, 48 V DC, 75 V DC, 120 V DC, 300 V DC, 500 V DC, 700 V DC

Control input: 4...32 V DC

Max. load current: 7 A, 20 A, 25 A, 40 A, 50 A, 80 A, 100 A

Type		DC switching			
Load voltage	Control voltage	Load current			
		7 A	20 A	25 A	40 A
36 V DC	4...32 V DC				RSR95-36D40-DC
48 V DC					RSR95-48D7-DC
75 V DC				RSR95-75D20-DC	RSR95-75D40-DC
120 V DC				RSR95-120D20-DC	RSR95-120D40-DC
300 V DC					RSR95-300D25-DC
500 V DC					RSR95-500D25-DC
700 V DC					RSR95-700D25-DC

Type		DC switching		
Load voltage	Control voltage	Load current		
		50 A	80 A	100 A
24 V DC	4...32 V DC	RSR95-24D50-DC		RSR95-24D100-DC
36 V DC			RSR95-36D80-DC	
48 V DC		RSR95-48D50-DC		
75 V DC			RSR95-75D80-DC	
500 V DC		RSR95-500D50-DC		
700 V DC		RSR95-700D50-DC		

Load voltage

	RSR95-24...	RSR95-36...	RSR95-48...	RSR95-75...
Rated load voltage	24 V DC	36 V DC	48 V DC	75 V DC
Rated range of load voltage	0...24 V DC	0...36 V DC	0...48 V DC	0...75 V DC

Load voltage

	RSR95-120...	RSR95-300...	RSR95-500...	RSR95-700...
Rated load voltage	120 V DC	300 V DC	500 V DC	700 V DC
Rated range of load voltage	0...120 V DC	3...300 V DC	3...500 V DC	3...700 V DC

Control input

Control voltage range	4...32 V DC
Must turn-on voltage	4 V DC
Must turn-off voltage	1 V DC
Maximum input current	25 mA 32 V DC
Maximum reverse voltage	32 V DC

Output circuit

	RSR95-24D50-DC	RSR95-24D100-DC	RSR95-36D40-DC	RSR95-36D80-DC	RSR95-48D7-DC	RSR95-48D50-DC	RSR95-75D20-DC	RSR95-75D40-DC	RSR95-75D80-DC
Load voltage range	0...24 V DC		0...36 V DC		0...48 V DC		0...75 V DC		
Maximum load current	50 A	100 A	40 A	80 A	7 A	50 A	20 A	40 A	80 A
Maximum surge current (at 10 ms)	150 A	250 A	120 A	200 A	30 A	150 A	60 A	120 A	200 A
Maximum on-state resistance	4,2 mΩ	2,1 mΩ	12 mΩ	6 mΩ	14 mΩ	7 mΩ	13 mΩ	13 mΩ	6,5 mΩ
Min. operational current	2 mA		2 mA		2 mA		2 mA		
Maximum off-state leakage current (at rated load voltage)	0,1 mA		0,1 mA		0,1 mA		0,1 mA		
Maximum turn-on time	0,3 ms		0,3 ms		0,3 ms		0,3 ms		
Maximum turn-off time	0,3 ms		0,3 ms		0,3 ms		0,3 ms		

❶ Data given for ambient temperature ≤ 25 °C. Above 25 °C the maximum current decreases - see "Thermal derating curves", pages 5-7.

Output circuit ①

	RSR95-120D20-DC	RSR95-120D40-DC	RSR95-300D25-DC	RSR95-500D25-DC	RSR95-500D50-DC	RSR95-700D25-DC	RSR95-700D50-DC
Load voltage range	0...120 V DC		3...300 V DC	3...500 V DC		3...700 V DC	
Maximum load current	20 A	40 A	25 A	25 A	50 A	25 A	50 A
Maximum surge current (at 10 ms)	60 A	120 A	75 A	75 A	150 A	75 A	150 A
Maximum on-state resistance	30 mΩ	30 mΩ	–	–	–	–	–
Min. operational current	2 mA		2 mA	2 mA		2 mA	
Maximum off-state leakage current (at rated load voltage)	0,1 mA		0,5 mA	0,5 mA		0,5 mA	
Maximum on-state voltage drop (at rated current)	–		1,75 V DC	1,75 V DC		1,75 V DC	
Maximum turn-on time	0,3 ms		0,3 ms	0,3 ms		0,3 ms	
Maximum turn-off time	0,3 ms		0,3 ms	0,3 ms		0,3 ms	

General data ①

Dielectric strength	input - output: 2 500 Vrms 50/60 Hz input, output - base: 2 500 Vrms 50/60 Hz
Minimum insulation resistance	1 000 MΩ 500 V DC
Ambient temperature (non-condensation and/or icing)	storage: -30...+100 °C operating: -30...+80 °C

Mechanical data

Dimensions (L x W x H)	58,6 x 45,7 x 33,5 mm with dust cover
Weight (typical)	100 g
Protection category EN 60529	IP 20
Connection mode	input: screws M3 ② tightening moment: 0,58...0,98 N•m output: screws M4 ② tightening moment: 0,98...1,37 N•m
Mounting on panel or heatsink ③	screws M4 tightening moment: 0,98...1,37 N•m

① Data given for ambient temperature ≤ 25 °C. Above 25 °C the maximum current decreases - see "Thermal derating curves", pages 5-7.

② When connection cables to relay: please ensure, screws are torqued down properly.

③ Relay must be mounted to proper sized heatsink, based on "Thermal derating curves". Between relay and heatsink must be used thermal pad.

Mounting, accessories for relays

Relays **RSR95** are designed for: • direct mounting on panel • mounting on heatsinks **RH**.
For **RSR95** relays we offer thermal pads **RTP-10**.

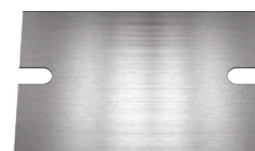

Thermal pad **RTP-10**

RSR95

solid state relays, industrial



RDR-10

RH21



RH19A



RH19B



Material	aluminum	aluminum	aluminum
Dimensions (L x W x H)	80 x 50 x 50 mm	70 x 50 x 69 mm	81 x 50 x 83 mm
Weight (typical)	115 g	275 g	335 g
Thermal resistance	2,1 °C/W	1,9 °C/W	1,9 °C/W
Additional equipment	–	RDR-10 ④	–
Mounting	on panel, on 35 mm rail mount	on 35 mm rail mount (with clip RDR-10)	on 35 mm rail mount

RH17A

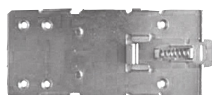

RDR-30



RH16



RH16-F



Material	aluminum	aluminum	aluminum
Dimensions (L x W x H)	90 x 50 x 69 mm	106 x 50 x 96 mm	106 x 80 x 96 mm
Weight (typical)	350 g	375 g	645 g
Thermal resistance	1,7 °C/W	1,6 °C/W	0,6 °C/W
Additional equipment	RDR-30 ⑤	–	built-in fan
Mounting	on 35 mm rail mount (with clip RDR-30)	on panel, on 35 mm rail mount	on panel, on 35 mm rail mount

RH08

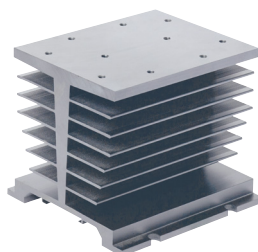

RH08-F



Material	aluminum	aluminum
Dimensions (L x W x H)	106 x 110 x 96 mm	106 x 140 x 96 mm
Weight (typical)	825 g	1 095 g
Thermal resistance	0,8 °C/W	0,35 °C/W
Additional equipment	–	built-in fan
Mounting	on panel, on 35 mm rail mount	on panel, on 35 mm rail mount

④ Clip RDR-10 for heatsink RH19A: for mounting on 35 mm rail mount (including 6 holes on M4 screws).

⑤ Clip RDR-30 for heatsink RH17A: for mounting on 35 mm rail mount (including 6 holes on M3 screws).

Thermal derating curves

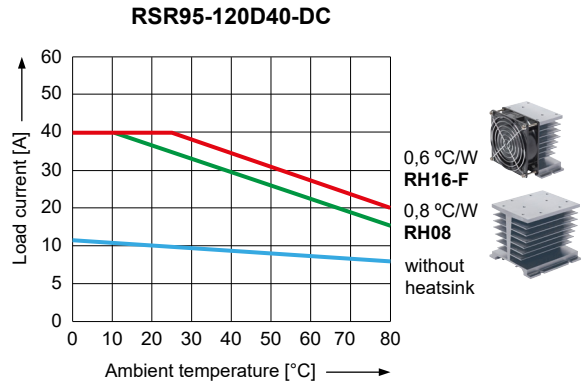
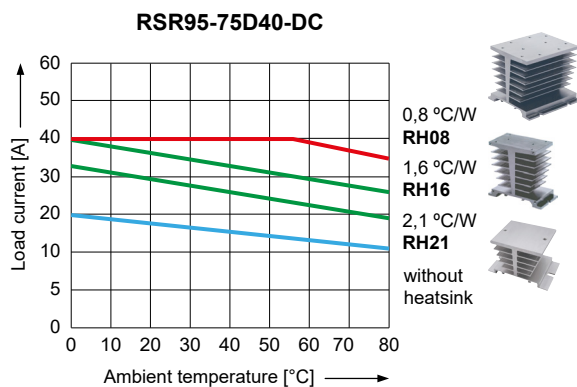
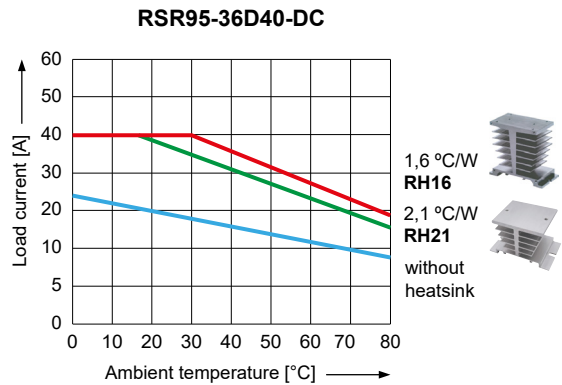
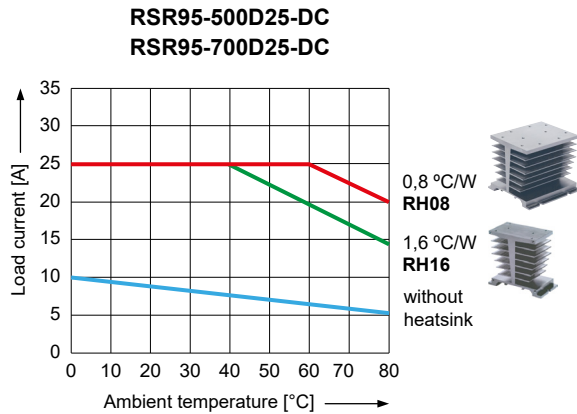
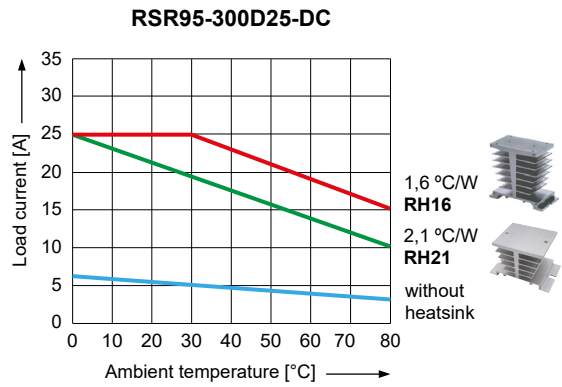
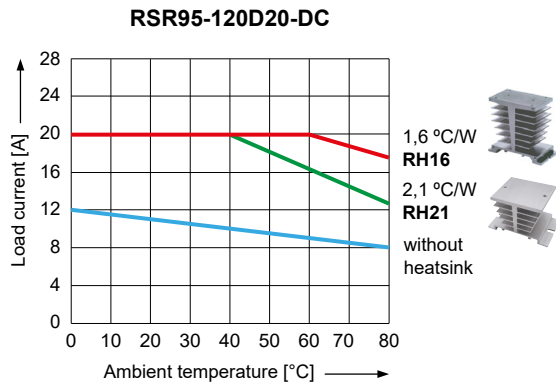
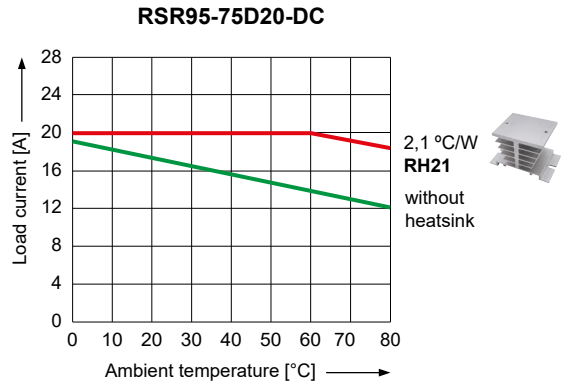
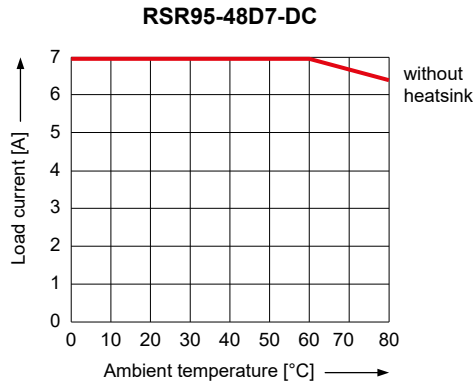

Thermal derating curves

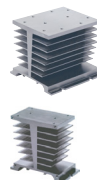
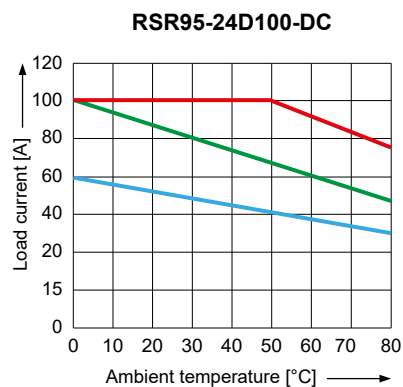
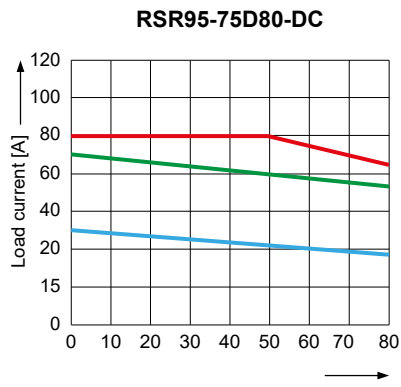
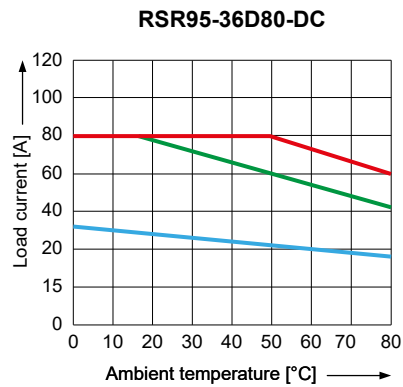
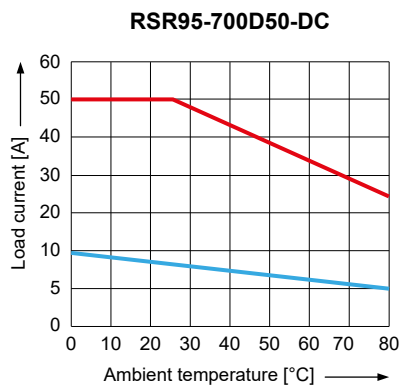
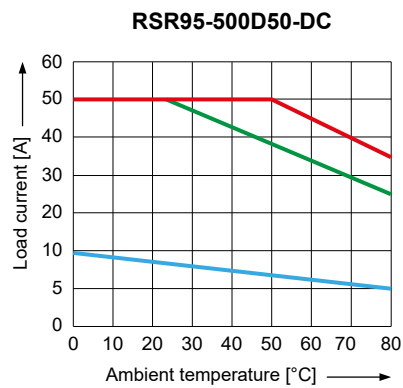
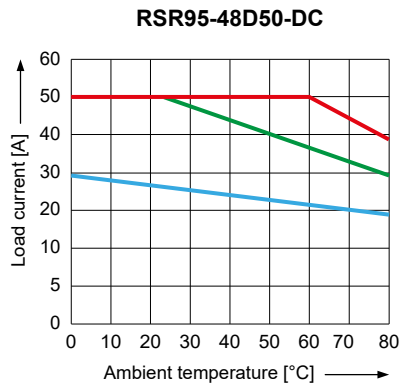
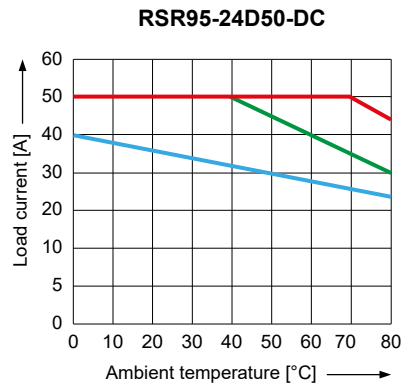

Thermal derating curves

To select the proper sized heatsink:

- determine the load current and the maximum ambient temperature the relay will be exposed to,
- use the "Thermal derating curves" (see above).

Example: for a **RSR95** 100 A, at 80 A load current and ambient temperature at 50 °C:

- on the Y axis we find the current value for which we draw a line perpendicular to Y,
- on the X axis we find the ambient temperature for which we draw a line perpendicular to X,
- we determine the intersection of both lines,
- read the heatsink rating – **always choose the rating above your point**: we need a 0,8 °C/W sized heatsink, since the 1,6 °C/W heatsink will not ensure sufficient cooling of the solid state relay.

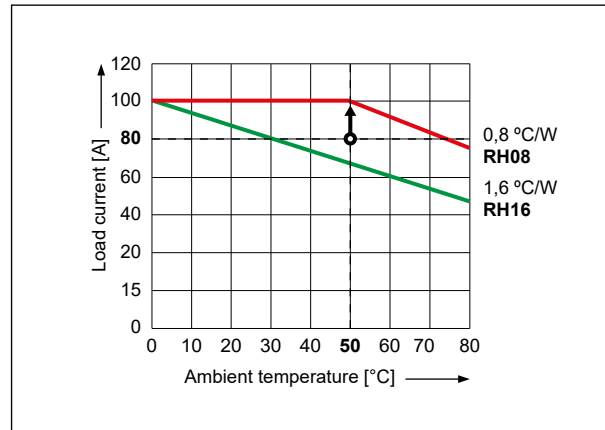

Dimensions

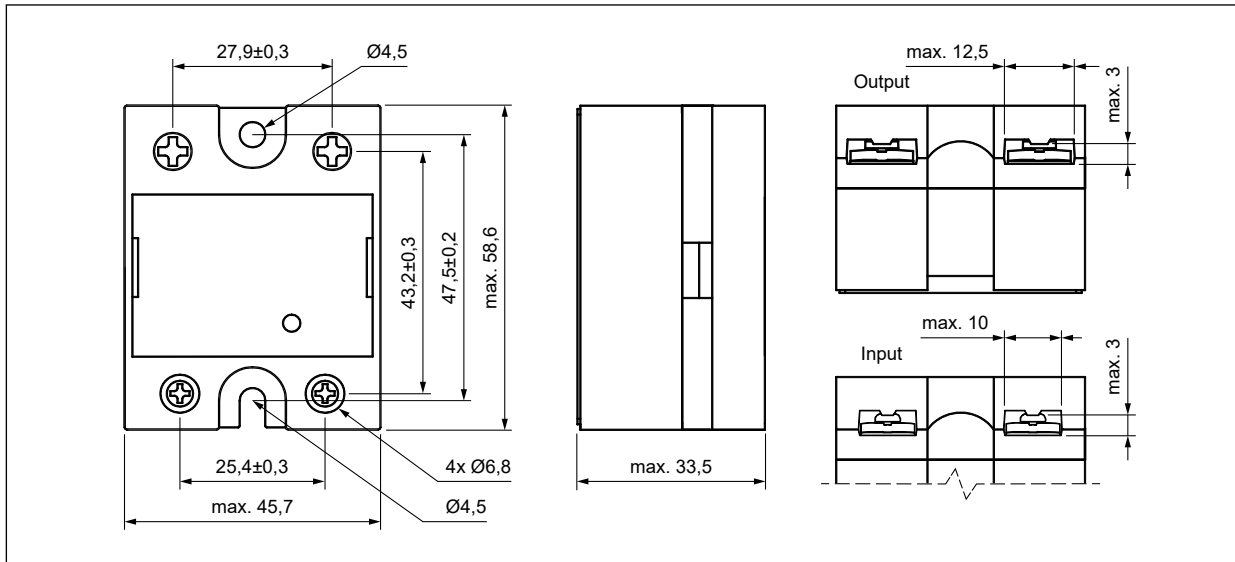

Solid state relay **RSR95**

Dimensions

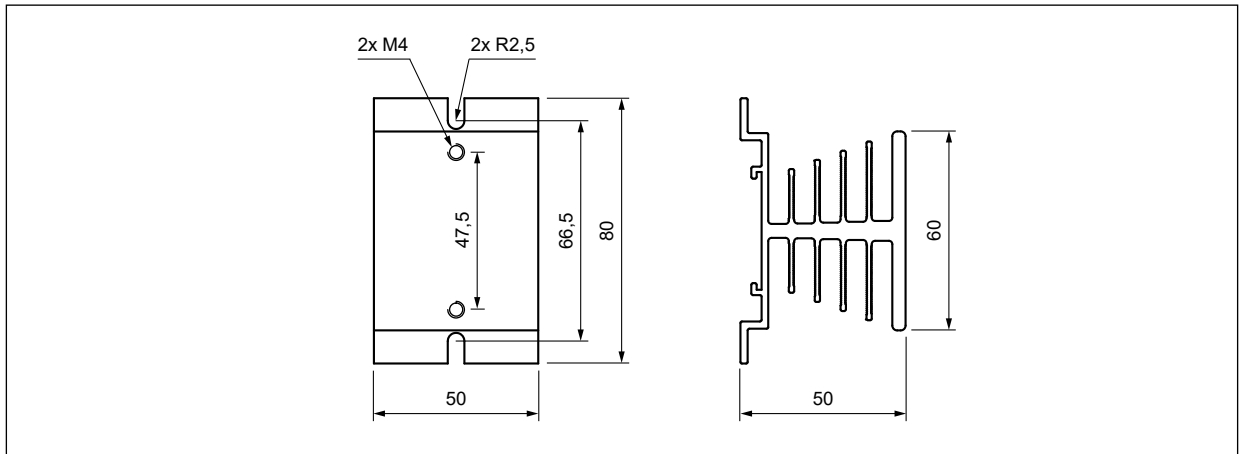

Heatsink **RH21**

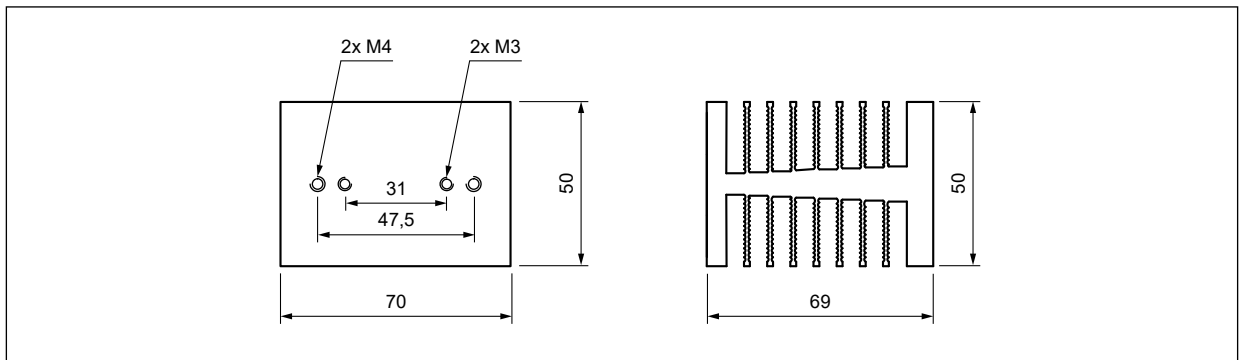

Heatsink **RH19A**

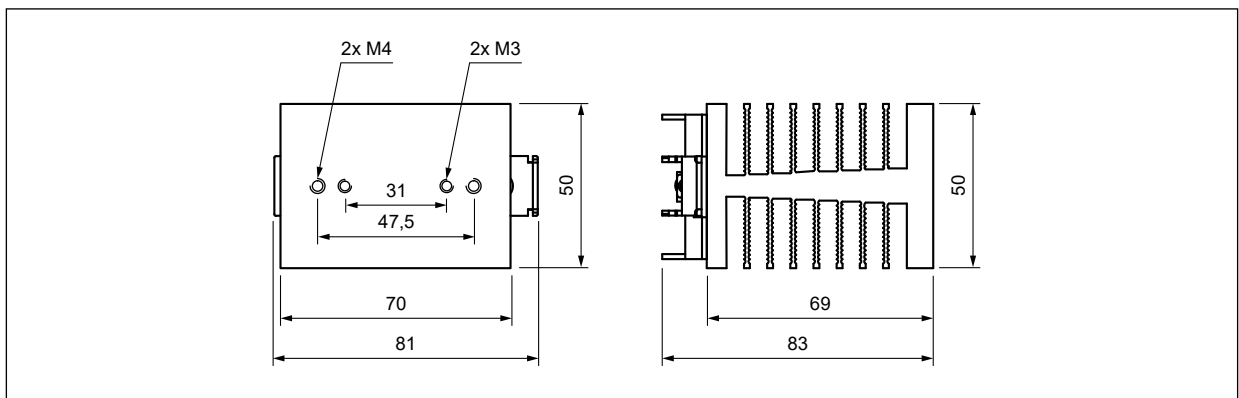

Heatsink **RH19B**

Dimensions

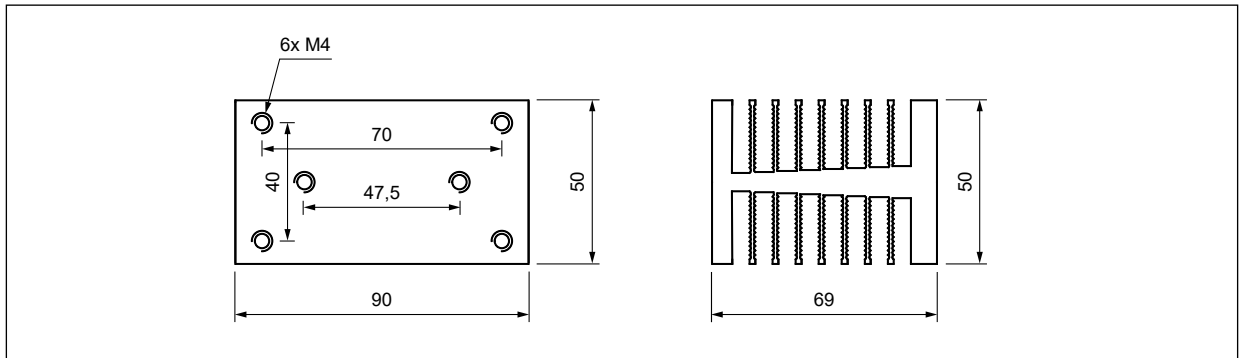

Heatsink **RH17A**

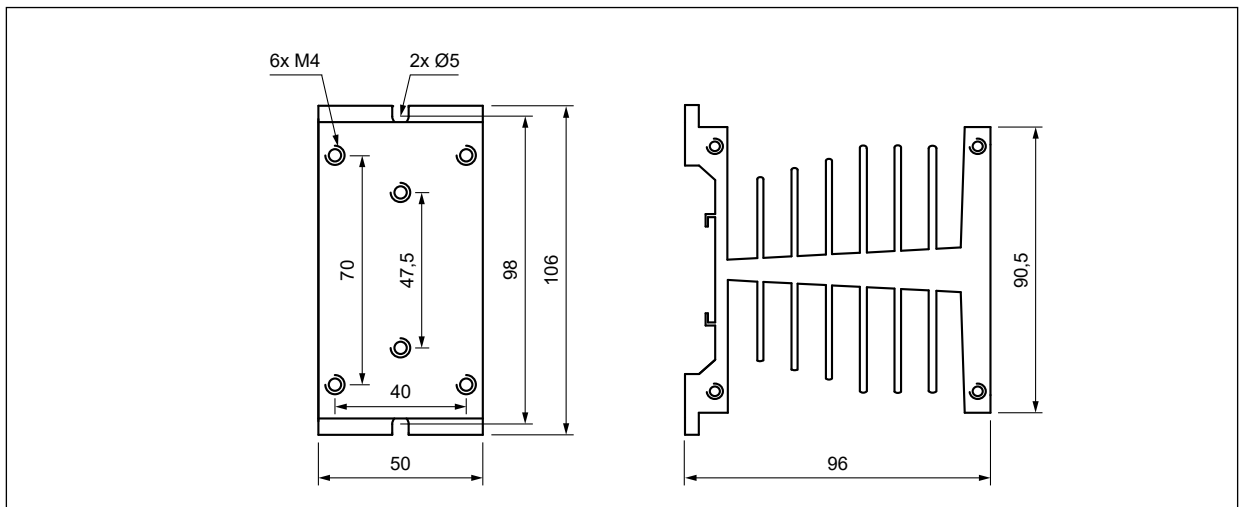

Heatsink **RH16**

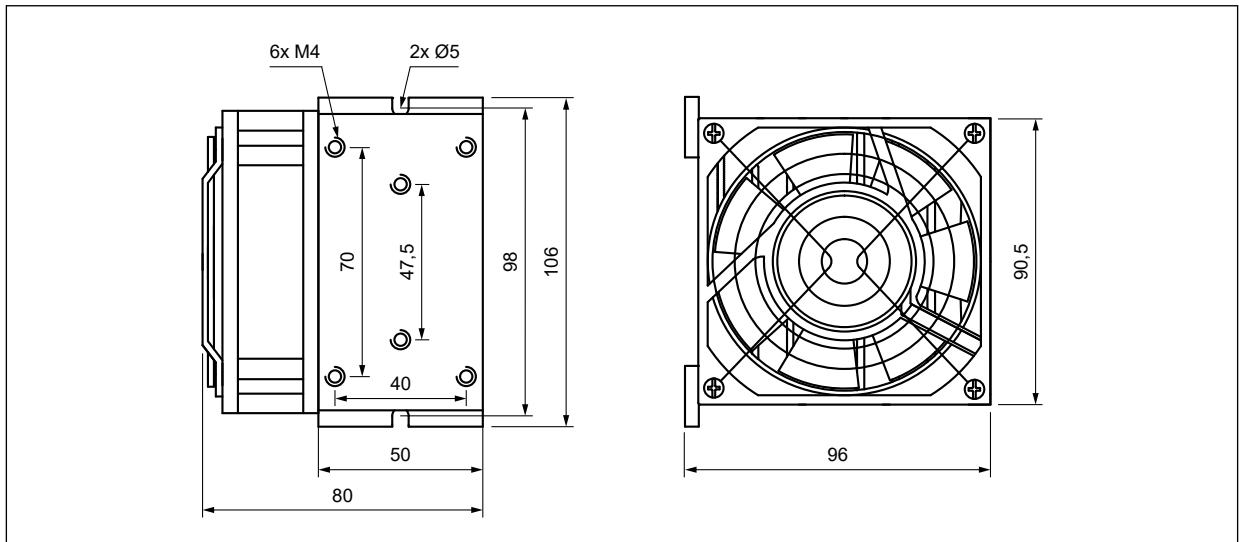

Heatsink **RH16-F**

Dimensions

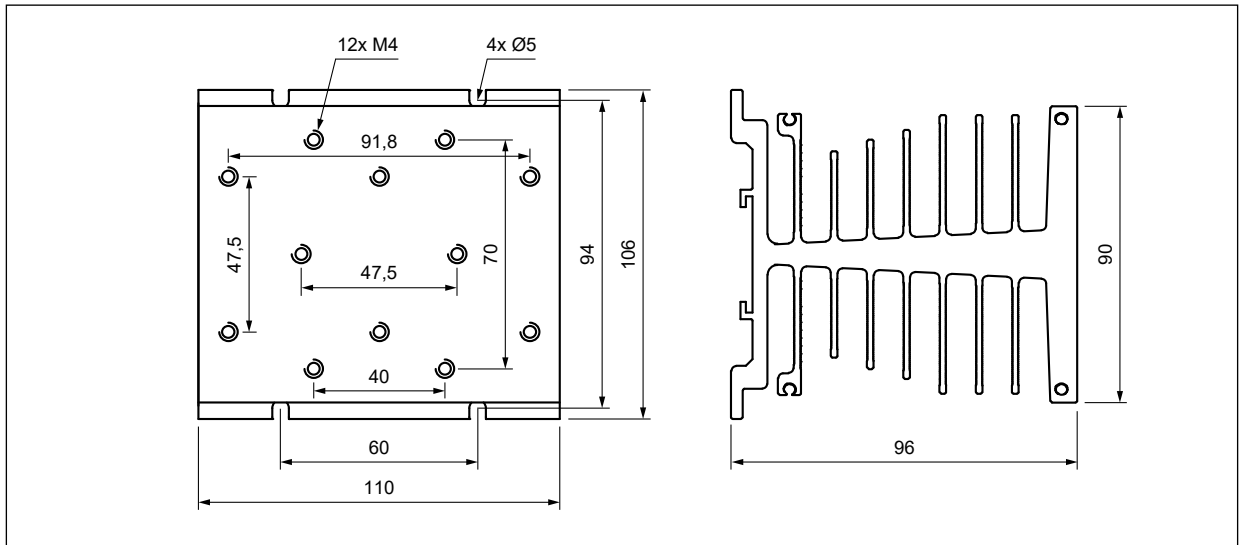

Heatsink RH08

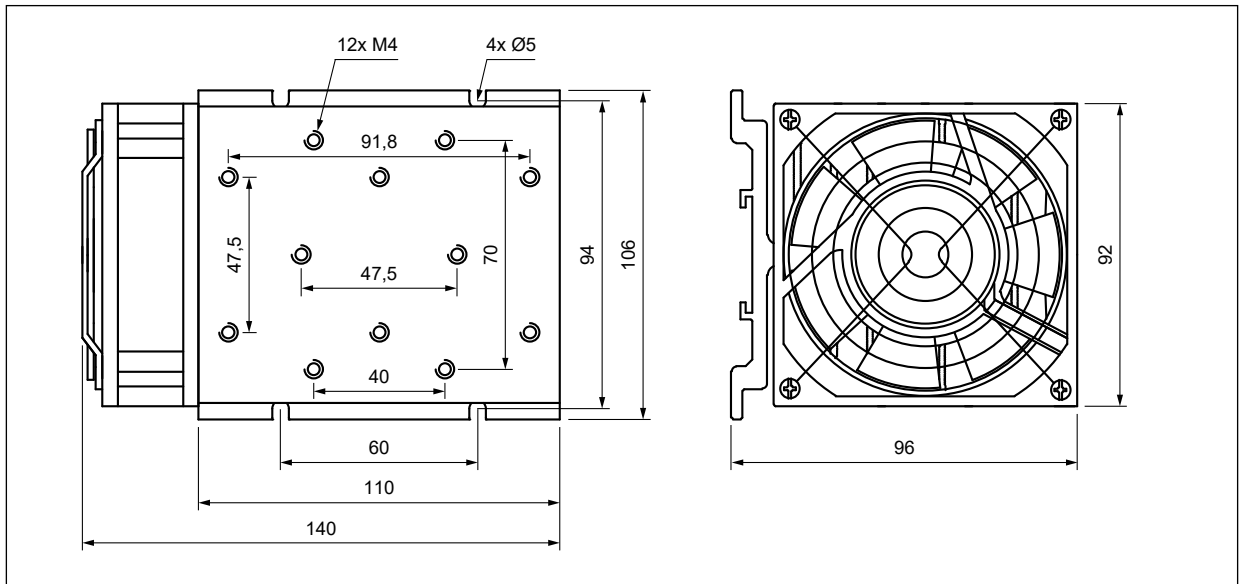

Heatsink RH08-F

Dimensions

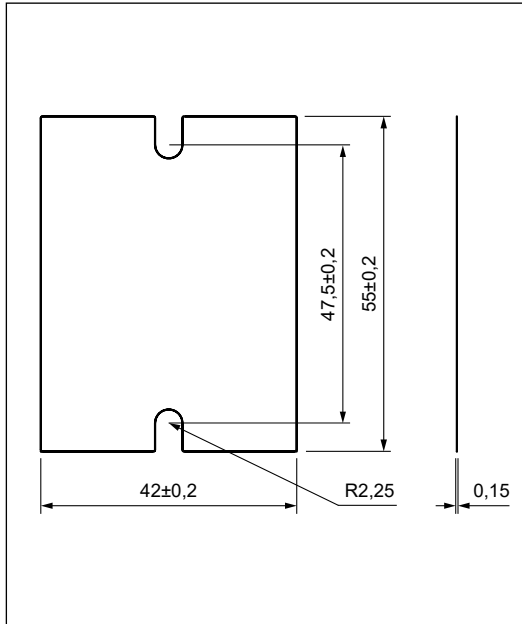

Thermal pad **RTP-10**

Connection diagram

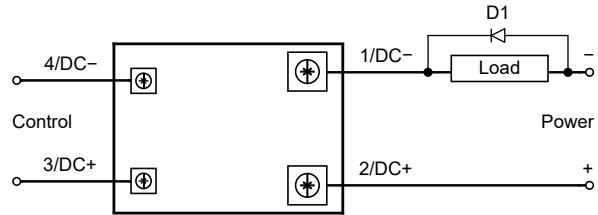

When solid state relay is used for inductive load control, please be sure to use a suppression circuit, just like the drawing above. Both load terminals are inverse paralleled with a freewheeling diode D1 .

Capacitive load will produce very high surge current at the moment of conduction, which may lead to the damage of solid state relay. Therefore, if the actual load is capacitive or the load has paralleled large capacitance, it is recommended that NTC should be connected in series in the load loop to suppress surge current.

D1: fast recovery diode (FRD)

Ordering codes

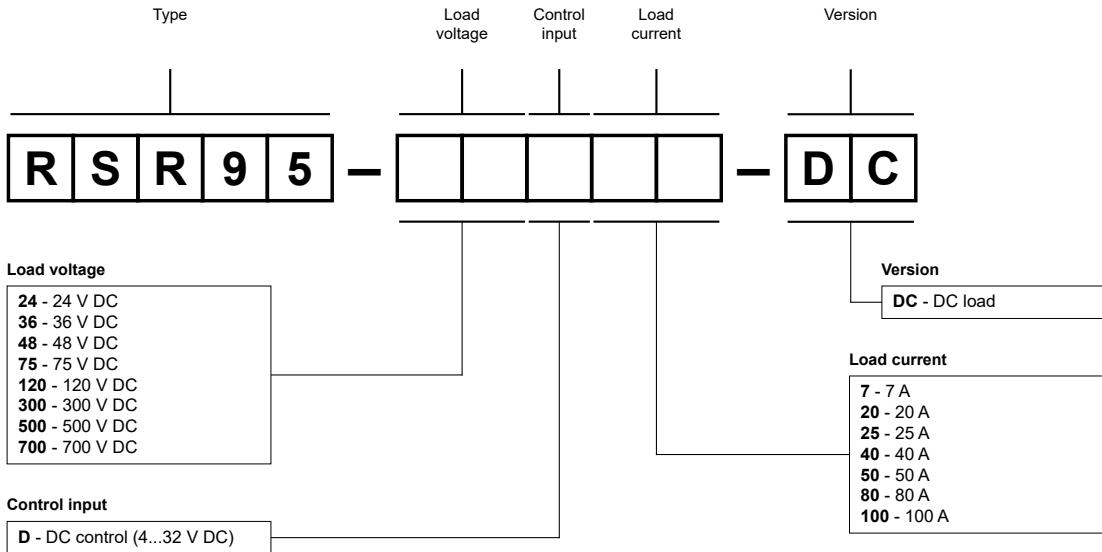

Examples of ordering codes ⑥:

- RSR95-48D7-DC** relay **RSR95**, DC load, DC control, load voltage 48 V DC, load current 10 A
- RSR95-120D40-DC** relay **RSR95**, DC load, DC control, load voltage 120 V DC, load current 40 A
- RSR95-700D50-DC** relay **RSR95**, DC load, DC control, load voltage 700 V DC, load current 50 A

⑥ Ordering codes **RSR95** are specified in tables "Type" on page 1.