

# MT-TWT-...

## time relays



- Time relays with independently controlled times T1 and T2, time function Wt (Monitoring of the sequence of pulses), 7 time ranges • Cadmium - free contacts • AC/DC input voltages
- Cover - modular, width 17,5 mm
- Direct mounting on 35 mm rail mount acc. to PN-EN 60715
- Applications: in low-voltage systems
- Compliance with standard PN-EN 61812-1
- Recognitions, certifications, directives: **CE ENEC**

### Output circuit - contact data

Number and type of contacts	1 CO		
Contact material	AgSnO <sub>2</sub>		
Max. switching voltage	400 V AC / 300 V DC		
Rated load	AC1	10 A / 250 V AC	
	DC1	10 A / 24 V DC; 0,3 A / 250 V DC	
Rated current	10 A / 250 V AC		
Max. breaking capacity	AC1	16 A / 250 V AC	
Min. breaking capacity	1 W 10 V, 10 mA		
Contact resistance	≤ 100 mΩ		
Max. operating frequency	600 cycles/hour		
• at rated load	AC1		
<b>Input circuit</b>			
Rated voltage	AC: 50/60 Hz AC/DC	12...240 V	terminals (+)A1 – (-)A2
Operating range of supply voltage	0,9...1,1 U <sub>n</sub>		
Rated power consumption	AC	≤ 4,5 VA AC: 50 Hz	
	DC	≤ 1,5 W	
Range of supply frequency	AC	48...63 Hz	
<b>Control contact S ①</b>			
• min. voltage ②	0,7 U <sub>n</sub>		
• min. time of pulse duration ②	AC: ≥ 50 ms	DC: ≥ 20 ms	
<b>Insulation according to PN-EN 60664-1</b>			
Insulation rated voltage	250 V AC		
Rated surge voltage	2 500 V 1,2 / 50 μs		
Overvoltage category	II		
Insulation pollution degree	1		
Flammability class	V-0 UL94		
Dielectric strength	• input - output	2 500 V AC	type of insulation: basic
	• contact clearance	1 000 V AC	type of clearance: micro-disconnection
<b>General data</b>			
Electrical life	• resistive AC1	> 0,5 x 10 <sup>5</sup>	10 A, 250 V AC
Mechanical life (cycles)	> 3 x 10 <sup>7</sup>		
Dimensions (L x W x H) / Weight	90 ③ x 17,5 x 63,5 mm / 64 g		
Ambient temperature	• storage	-40...+70 °C	
	• operating	-20...+45 °C	
Cover protection category	IP 20	PN-EN 60529	
Relative humidity	up to 85%		
Shock / vibration resistance	15 g / 0,35 mm 10...55 Hz		
<b>Time module data</b>			
Functions	Wt		
Time ranges	1 s ④; 10 s; 1 min.; 10 min.; 1 h; 10 h; 100 h		
Timing adjustment	smooth - (0,1...1) x time range		
Setting accuracy	± 5% ⑤ ⑥		
Repeatability	± 0,5% ⑥		
Values affecting the timing adjustment	• temperature	± 0,05% / °C	
	• humidity	± 0,05% / %HR	
Recovery time	≤ 50 ms		
LED indicator	green LED U ON - indication of supply voltage U green LED U slow flashing - measurement of T1 time green LED U fast flashing - measurement of T2 time yellow LED R ON/OFF - output relay status		

① The control terminal S is activated by connection to A1 terminal via the external control contact S. ② Where the control signal is recognizable. ③ Length with 35 mm rail taps: 98,8 mm. ④ For first range setpoint (1 s) setting accuracy and repeatability are smaller than the given ones in technical parameters (significant influence of the operational relay operating time, processor start-time, and the moment of supply switching as referred to the AC supply course). ⑤ Calculated from the final range values, for the setting direction from minimum to maximum.

# MT-TWT-...

## time relays

### Time functions

**Wt** - Monitoring of the sequence of pulses. Switching on is extended with consecutive pulses / closings of the contact S. Independent settings of T1 and T2 intervals.

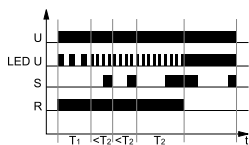

On applying the supply voltage U the output relay R is switched on for the set interval T1. After the interval T1 has lapsed, the interval T2 starts with the output relay R still switched on. For the output relay to switch on, the control contact S must be closed and then opened (single pulse) during the interval T2, which cancels the time already measured and starts the interval T2 again. In case of absence of a single pulse prior to lapse of the interval T2, the output relay R will switch off, and it may be switched on after the supply voltage has been interrupted and applied again.

U - supply voltage; R - output state of the relay;  
S - control contact state; T1, T2 - measured times; t - time axis

### Additional functions

**Supply diode:** it is lit permanently when the time is not being measured. In course of the T1 time measurement, it flashes at 500 ms period where it is lit for 80% of the time, and off for 20% of the time. For the T2 time, the period is 250 ms.

**Adjustment of the set values:** the values of time and range are read in the course of the relay's operation. The set values may be modified at any moment.

**Release:** the relay is released by connection of the S contact to the A1 line. For DC supply, the positive pole must be connected to the A1 line. The level of the S contact activation is adjusted automatically depending on the supply voltage.

**Supply:** the relay may be supplied with DC voltage or AC voltage 48...63 Hz of 10,8...250 V. A programmed control of the supply voltage has been applied so the processor shall not start operation if the voltage is lower than approximately 10 V. The supply voltage is permanently monitored in course of the operation of the relay. When the voltage drops below 9 V for more than 50 ms, the relay shall be reset. Owing to this, the regeneration time is programmed to 50 ms, and it does not depend on the tolerance of the elements.

### Dimensions

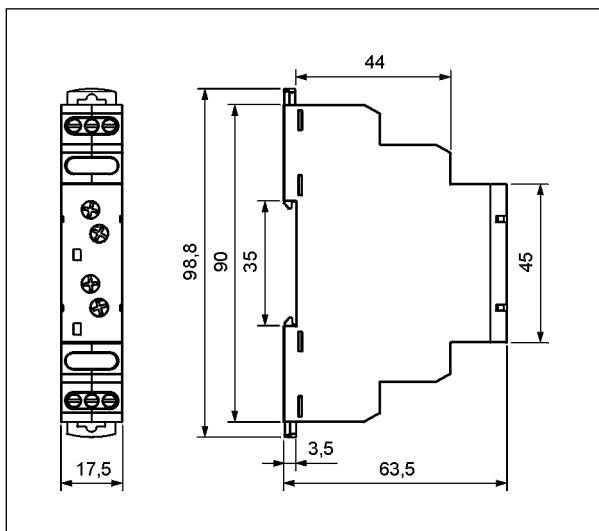

### Front panel description

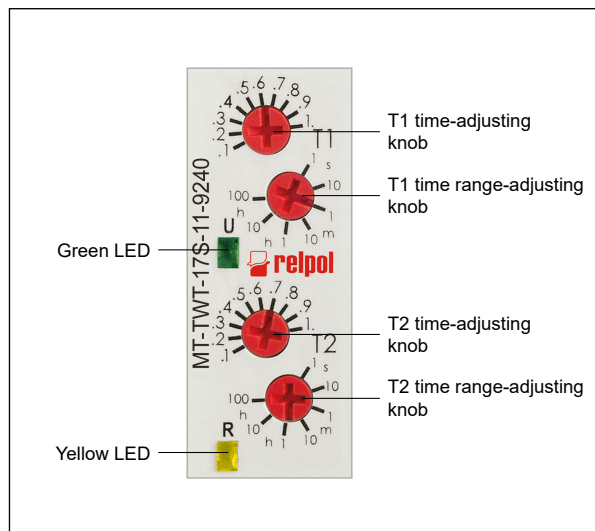

## Connection diagram

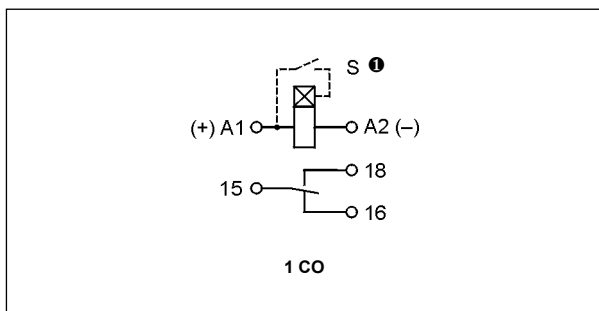

❶ The control terminal S is activated by connection to A1 terminal via the external control contact S.

## Mounting

Relays **MT-TWT-...** are designed for direct mounting on 35 mm rail mount acc. to PN-EN 60715. Operational position - any. **Connections:** max. cross section of the cables: 1 x 2,5 mm<sup>2</sup> / 2 x 1,5 mm<sup>2</sup> (1 x 14 / 2 x 16 AWG), length of the cable deinsulation: 6,5 mm, max. tightening moment for the terminal: 0,6 Nm.



**Two taps:**  
easy assembly on 35 mm rail,  
firm tapping (top and bottom).

## Ordering codes

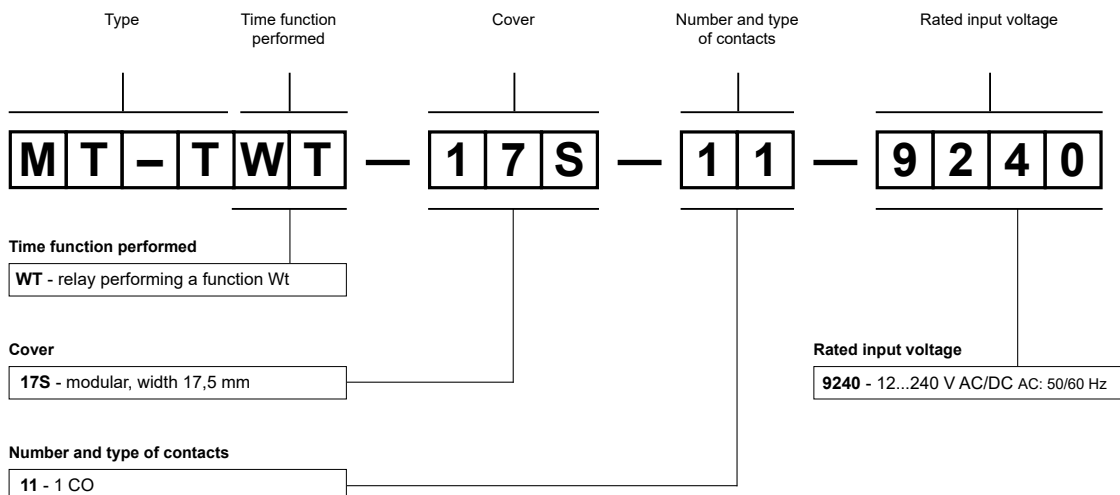

Example of ordering code:

**MT-TWT-17S-11-9240**

time relay **MT-TWT-...**, single-function (relay perform function Wt), cover - modular, width 17,5 mm, one changeover contact, contact material AgSnO<sub>2</sub>, rated input voltage 12...240 V AC/DC AC: 50/60 Hz

### PRECAUTIONS:

1. Ensure that the parameters of the product described in its specification provide a safety margin for the appropriate operation of the device or system and never use the product in circumstances which exceed the parameters of the product. 2. Never touch any live parts of the device. 3. Ensure that the product has been connected correctly. An incorrect connection may cause malfunction, excessive heating or risk of fire. 4. In case of any risk of any serious material loss or death or injuries of humans or animals, the devices or systems shall be designed so to equip them with double safety system to guarantee their reliable operation.